

Small-sized micro differential pressure transmitter

- This is a small-sized/light-weight type micro differential pressure transmitter.
- A silicone rubber piece with small hysteresis is used in the sensor part.
- The zero adjustment trimmer provided on top facilitates zero adjustment as of after installation.



EMT6

List of products

WO81

WO71

FR51A

MS99

MS99S

MS61A-RA

QDP33

EMD8A

EMD7

EMT1

EMTGP1

EMT1H

EMT6

EMP5A

EMRT1

HWS15A

Accessories

Application

Precautions

Maintenance

<Main application fields>

- Semiconductor manufacturing equipment
- Negative pressure for dust collector/differential pressure of air conditioners
- Filter pressure loss management
- Precision machine manufacturing line
- General factory management equipment

<Usage>

- Measurement of internal pressure of indoor device
- Detection of clogging of air filter
- Measurement of clogging of bug filter
- Measurement of dynamic pressure at ventilation/exhaust device
- Room pressure measurement in a clean room

*(Refer to pages 114 to 117)

Product code

EMT6 **B 0 FV D 100 V** (Example)

Pressure range code: **100**

Mounting orientation: **V** (Range for specification of vertical mounting), **H** (Range for specification of horizontal mounting), None (Range for arbitrary mounting)

Range: **100** (Maximum value)

Unit: **D** (Pa), **E** (kPa)

Base: **FV** (For vinyl pipe)

Output: **0** (Two-wire type 4-20 mA DC)

External shape: **B** (Exposed terminal type)

- ◆ When making an inquiry or placing an order, specify the above product code.
- ◆ When you use this product for airflow rate/airflow speed measurements, we need to obtain the specifications of the pressure detection side. Fill out the airflow rate/airflow speed specification document preparation sheet on page 15 and inform us of the data.

Mounting orientation and range

0 to 50 Pa, 0 to 100 Pa, 0 to 200 Pa, 0 to 300 Pa

It is necessary to specify the mounting orientation (horizontal, upright, and others) at the time of order placement.

Whole range other than on the left

The transmitter can be mounted at arbitrary angle between horizontal and upright.

The instrument can be mounted on the mounting surface in an arbitrary manner.

Specifications

Model	EMT6				
Pressure unit	Pa, kPa		Operating ambient humidity	90% RH or below (no condensation allowed)	
Pressure measurement method	Differential pressure method		Durable vibration	5 to 10 Hz, amplitude of 10 mm, 10 to 50 Hz, acceleration of 39 m/s ² (two hours each for three axial directions)	
Measured gas	Air and noncorrosive gas (liquid cannot be measured)		Durable impact	100 m ² (six times each for three axial directions)	
Pressure-receiving element	Diaphragm (silicone rubber)		Compatible pipe	Vinyl pipe or rubber pipe (inner diameter of 4 mm)	
Withstanding pressure of pressure-receiving element	10 kPa (refer to page 118)		Polarity of piping connector	Indicating high-pressure side and low-pressure side with "H" and "L" marks, respectively, at the piping connection part.	
Instrument body withstanding pressure	50 kPa (refer to page 118)		Mass	Approx. 110 g	
Exterior material	Polyamide				
Electric signal conversion method	Variable inductance				
Insulation resistance	Between terminal and case: 20 MΩ or higher (500 V DC megger)				
Operating ambient temperature	0°C to 50°C (no freezing allowed)				
Pressure range code	Pressure range	Mounting orientation	Accuracy (at 20°C)	Temperature characteristics (zero + span) at 0°C to 50°C	Output and transmission method
D 50 H D 100 H D 200 H D 300 H	0–50 Pa 0–100 Pa 0–200 Pa 0–300 Pa	Horizontal (specification)	±2.5% FS	±0.15% FS/°C	Two-wire type: Output signal of 4 to 20 mA DC (load resistance of 500 Ω or lower) Power voltage of 24 V DC ± 10% (ripple of 0.2 V P-P or lower)
D 50 V D 100 V D 200 V D 300 V	0–50 Pa 0–100 Pa 0–200 Pa 0–300 Pa	Upright (specification)			
D 500 D 1000 E 2 E 3 E 5	0–500 Pa 0–1000 Pa 0–2 kPa 0–3 kPa 0–5 kPa	Between horizontal and upright Arbitrary mounting			

◆When using this product in a combustible gas atmosphere, use the intrinsically safe type EMT1H described on page 85.

◆For the use environment, refer to page 118.

External dimension drawing

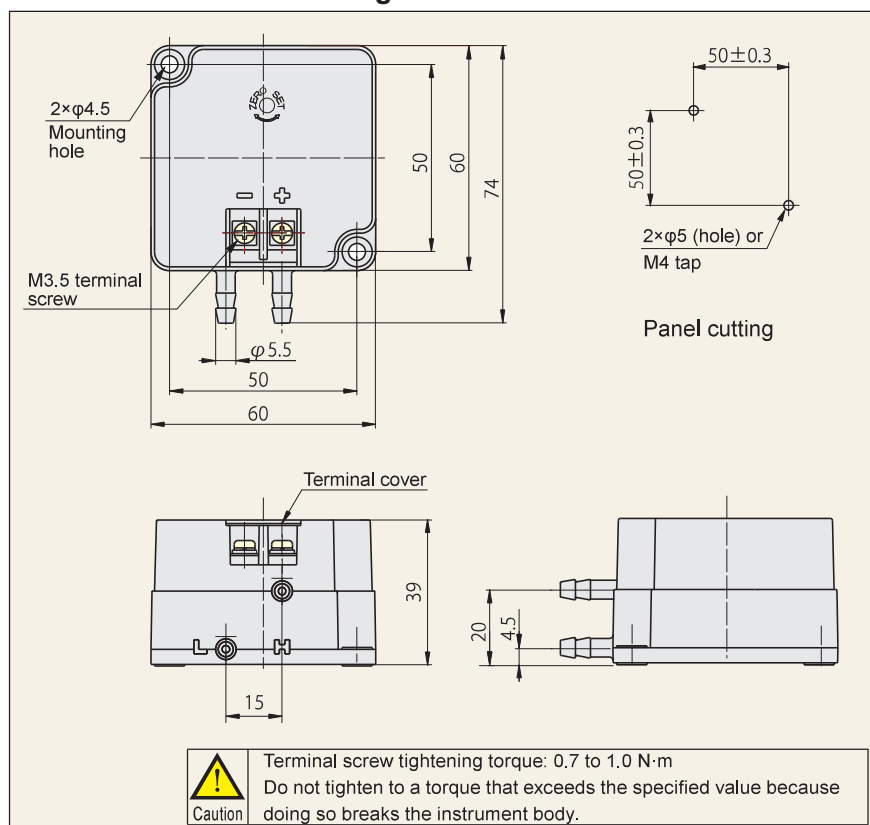

Terminal connection diagram

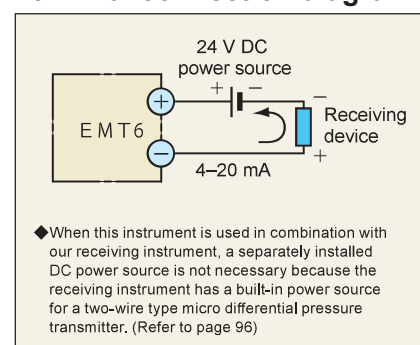

Transmission output diagram (pressure-output signal)

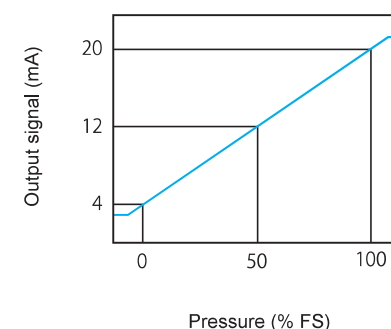

Warranty

Warranty period

The warranty period for our product is one (1) year from delivery to the location specified by the orderer who makes a direct transaction with us.

Scope of warranty

If any failure or defect attributable to us becomes clear during the above warranty period, we will repair the product or supply a substitute product free of charge. However, even during the warranty period, we will exclude the product from the scope of the warranty if the failure or defect corresponds to any of the following:

- (1) The failure or defect was caused by an unreasonable condition, environment, handling, or usage not mentioned in the instruction manual, specifications, and our product catalog.
- (2) The failure or defect was caused by a factor other than our product.
- (3) The failure or defect was caused by a modification or repair conducted by a party other than us.
- (4) The failure or defect was caused by an event that could not be foreseen at the scientific and technical levels at the time of product shipment from us.
- (5) The failure or defect was caused by an external factor not attributable to us, such as acts of God and disasters.

Please note that the warranty mentioned here means the warranty for our individual product, and damage provoked by a failure or defect of the product is excluded from the scope of the warranty.

*This warranty is valid only in Japan.

Application and usage

Our products are designed and manufactured as general-purpose instruments for general industries.

Therefore, our products are not intended for the following uses, and our products used in such a manner are outside the scope of application.

- (1) Equipment that is anticipated to greatly affect lives and properties, such as nuclear power generation, aviation, railways, marine vessels, vehicles, and medical devices
- (2) Utilities that include electricity, gas, and service water
- (3) Use in outdoor locations and under similar conditions or environments other than those stipulated in the instruction manual
- (4) Usage to which considerable safety consideration and attention equivalent to (1) and (2) above need to be given

Service

Scope of service

Because the product price does not include service expenses, such as the dispatch of engineers, we will separately charge for the expenses in the following cases:

- (1) Instruction for installation and adjustment and a witnessed test run
- (2) Maintenance inspection, adjustments, and repairs
- (3) Technical guidance and technical education
- (4) Witnessed inspections of products at our factory

<<Note>> The product specifications and information in this catalog are subject to change without prior notice for product improvement or other reasons.

● For order placement, contact

General
agent



Manostar Co., Ltd.

1-2-3 Nishishiraike-cho, Nagata-ku, Kobe City, Hyogo 653-0031
TEL. +81-78-621-7000 FAX. +81-78-621-7788

Manufacturer



Yamamoto Electric Works Co., Ltd.

1-2-3 Nishishiraike-cho, Nagata-ku, Kobe City, Hyogo 653-0031
TEL. +81-78-631-6000 FAX. +81-78-631-6020